

		REVISIONS			MICRO FILMED
ZONE	LTR	DESCRIPTION	DATE	APPROVED	
	A	ADDED BRACKET ASS'Y NOTE & PC. 68	5/6/70	E.A.S.	
	B	ADDED NOTE 2	5/22/70		
D-8	C	REVISED NOTE ON BRGS. - PC. 38	8/25/70		
B-2	D	ADDED FILL CAP ASSEMBLY NOTE.	11/13/70		
D-3	E	ADDED NEW DESIGN FRONT HEAD.	12/22/70		
	F	ADDED J10X BRG. DATA. PC. 24 & 73	5/6/71		
	G	ADDED PC. 74	8/2/71	E.S.	
B-3	H	ADDED PC. 75	11/8/71	E.S.	
B-8	I	REMOVED PC. 57 & ADDED NOTE.	8/8/72	G.L.	
B-8	J	REMOVED REF. TO LOCTITE UNDER SLEEVE NOTE.	3/29/73	EMS	
A-4	K	ADDED CLEAR. NOTE FOR 350°F & OVER	5/7/74	EMS	
D-8	L	ADDED EXPLODED VIEW OF THRUST BRG.	6/23/77	JJR	JUN 29 1977
A-7	M	ADDED PC. 76	12/10/80	EMS	DEC 17 1980
ALL	N	REDRAWN ON CAD & PICTORALLY UPDATED. ADDED PCS 57, 66, 77, 83, 84 & 85.	D.T./AAG 9/16/91	R A S	OCT 31 1991
C-2	P	ADDED VIEW C-C & TABULATION FOR SPLIT DOWELS. (IECR NO. 7260)	D.T./RD 8/9/94	WDP	AUG 17 1994

TABULATION	
PUMP SIZE	'X' DIM.
J-10X	1.00
J-20X	1.00
J-30X	1.00
J-40X	1.25
J-50X	1.50
J-60X	1.50
J-70X	2.00
J-80X	2.38

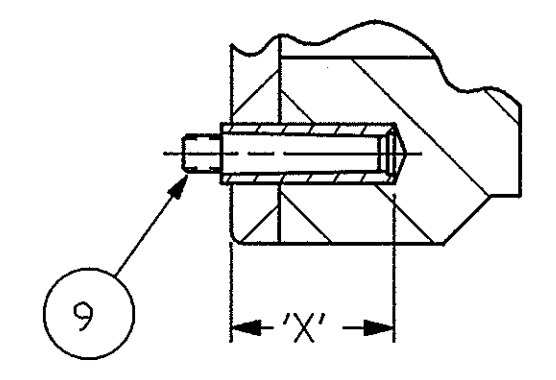

VIEW C-C
SPLIT DOWEL

DRILL & REAM FOR SPLIT DOWEL
(NOM DIA $\begin{matrix} +0 \\ -.001 \end{matrix}$) TO 'X' DIM.
FOR APPLICABLE PUMP SIZE

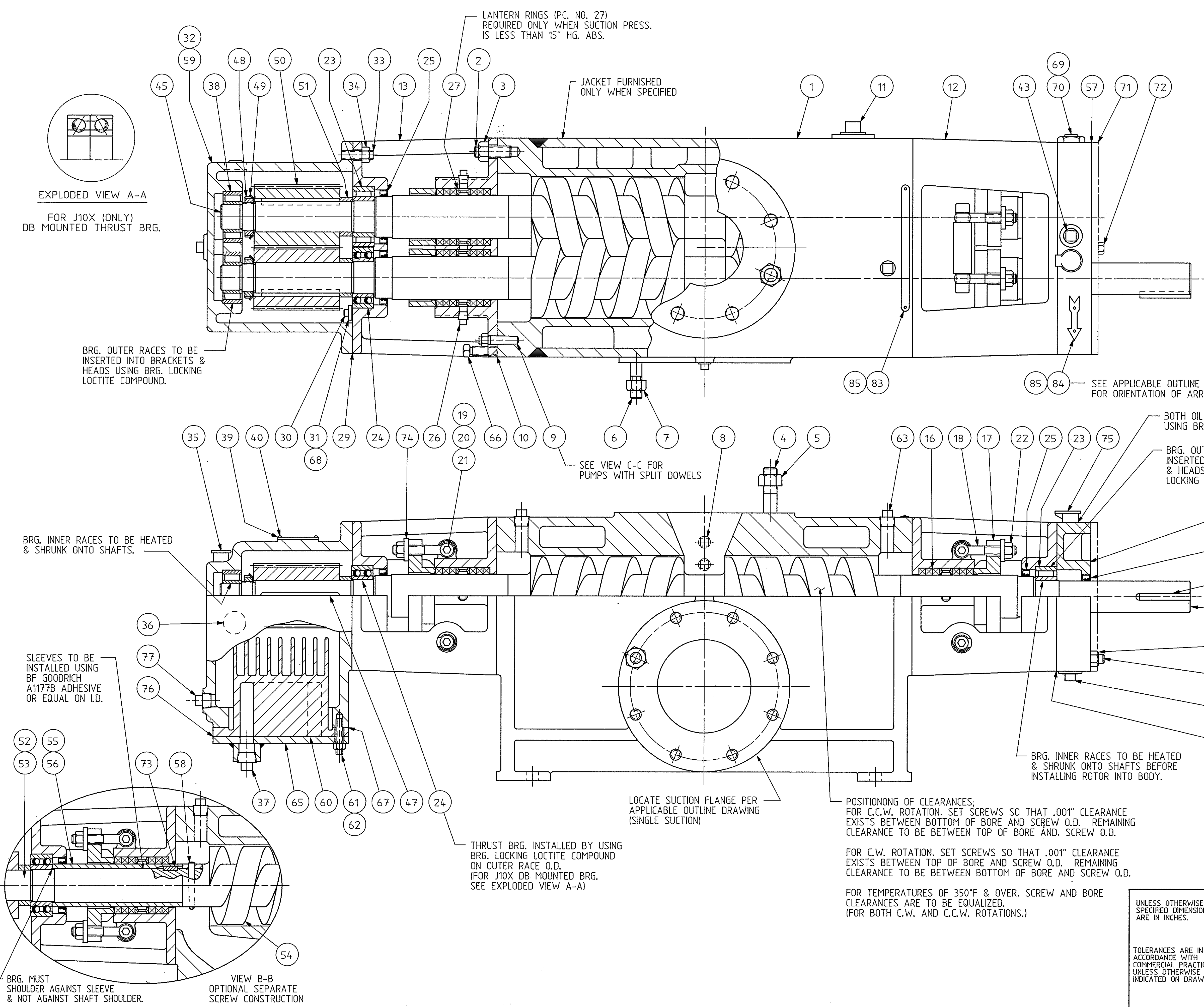

NOTE 1:
FRONT BRACKET ASSEMBLY - J-30X & J-60X

FRONT HEAD 002B0358 FITS FRT. BRG. BRKT. OF BOTH J-20X & J-30X PUMPS. ON THE J-30X, NOTE THAT STUDS ON FRONT FACE OF BRKT. ARE ORIENTED CLOSER TO ONE END OF THE BRKT FLANGE. ASSEMBLE J-30X FRONT BRKT WITH STUDS OFFSET TOWARD LONG SHAFT SIDE. THE FRONT BRKT. FOR THE J-20X CAN BE MOUNTED EITHER WAY SINCE THERE IS NO OFFSET.

FRONT HEAD 002B0359 FITS FRT. BRG. BRKT. OF BOTH J-50X & J-60X PUMPS. THE J-60X FRONT BRKT. MUST BE ASSEMBLED WITH STUDS OFFSET TOWARD LONG SHAFT SIDE. THE FRONT BRKT FOR THE J-50X CAN BE MOUNTED EITHER WAY.

UNLESS OTHERWISE SPECIFIED DIMENSIONS ARE IN INCHES.		CONTRACT NO. R A SMIGIEL A.Z.		2/11/70		DATE		 Imo Industries Inc. Warren Pumps Inc. Warren, MA, USA 01083-0969	
TOLERANCES ARE IN ACCORDANCE WITH COMMERCIAL PRACTICE UNLESS OTHERWISE INDICATED ON DRAWING		CHECKED	A.G.	2/11/70		DATE		TYPICAL SECTIONAL ASSEMBLY FOR JAGUAR X SCREW PUMPS	
		DRAWN	E.S.	1/25/70		DATE		SIZE D	
		APPROVED		CAGE CODE 63857	ESWS	DRAWING NO. A-1828	REV P	SHEET 1 OF 1	

DRAWING NO. A-1828 SHEET 1 OF 1